

Product No. 1025-1



The Spring Street Series
Hook Arm Sconce
Extra Large

AMERICA'S FINEST 
Lighting & Mailbox Co.

X Large

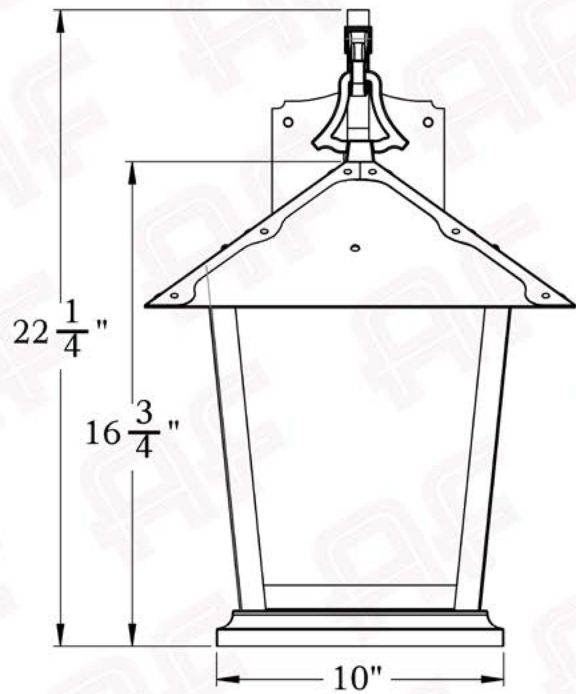

FRONT VIEW

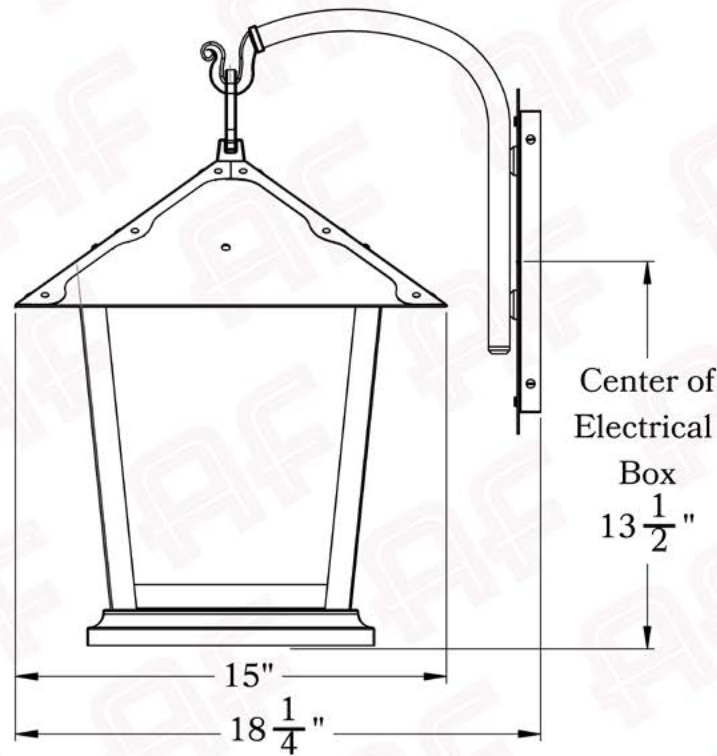

SIDE VIEW

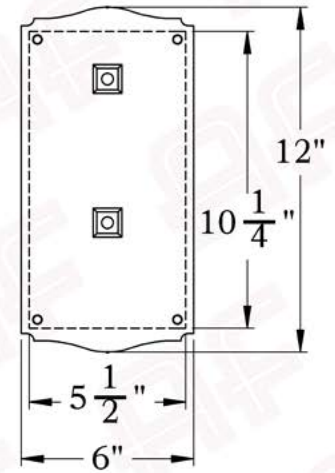

BACKPLATE VIEW

Dimensions

Roof Width	15"
Body Width	10"
Lantern Height	16 3/4"
Height	22 1/4"
Projection	18 1/4"
Mounting Plate	6" x 12"

Electrical Specs

UL Rating	Damp
Voltage	120V
Socket Type	Medium Base - E26
Number of Light Bulbs	1
Max Wattage per Bulb	100W
LED Bulb	Supplied
Dimmable	Yes

Additional Information

Manufacturer	America's Finest Lighting
Mounting Location	Interior and Exterior
Material	Brass
Multiple Overlay Options	Yes
Bottom Glass Panels	Included

Overlays Available In This Series



Trellis



Lattice



Cross



Trellis with Ivy



Lattice with Ivy



Glass Only

Mounting Instructions | Wall Mount With Fire Pan

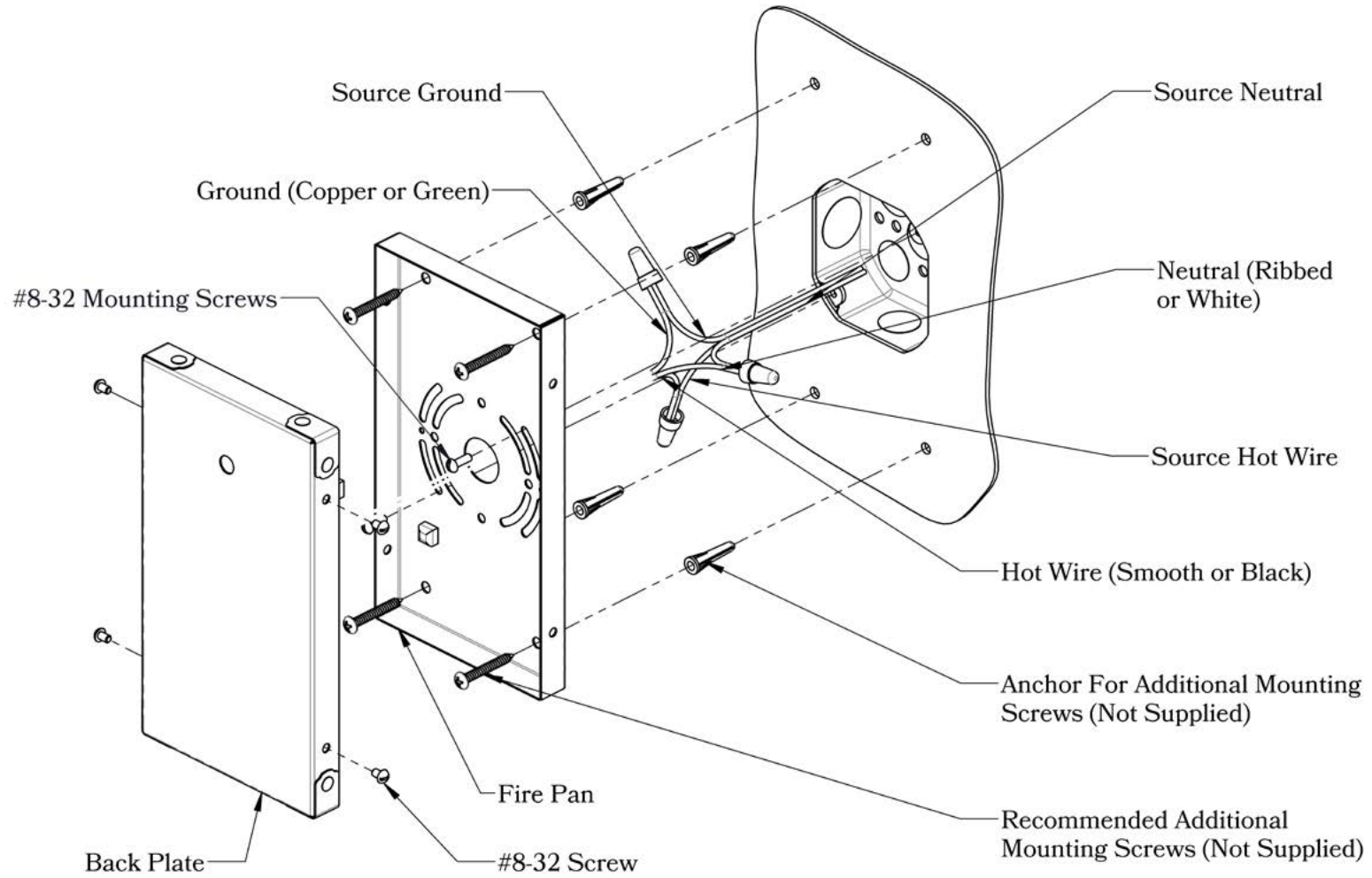

CAUTION—DISCONNECT POWER

Always shut off power when installing or repairing this (or any other) electrical appliance. Failure to do so may result in severe injury or death. This product must be installed in accordance with applicable installation codes by a person familiar with the construction and operation of the product, and the hazards involved.